



- Self-cleaning
- High spray dwell time
- Identical to Tempest & Typhoon for maintenance purpose

Recommended

working pressure:	4 - 10 bar (58 - 145 psi)
Cleaning diameter:	max. 27 m (88.6 ft)
Flow rate:	14.6 - 22.7 m ³ /h (243 - 378 l/min / 64.3 - 99.9 USgpm)
Spray angle:	360°
Operating temperature:	max. 95 °C (203 °F)
Ambient temperature:	max. 140 °C (284 °F), 30 min
Insertion opening:	min. Ø 220 mm (8.66 inch)
Materials:	stainless steel 316L (1.4404), C-PTFE or PTFE
Weight:	approx. 3.1 kg (6.8 lbs)
Preferred mounting position:	any

Approx. cycle times

Pressure	Nozzles Ø 11 mm
4 bar	11 min 45 s
6 bar	7 min 30 s
8 bar	6 min 15 s
10 bar	5 min 30 s

Version 1

Version 1	Part number
1 1/2" BSP / 11 mm nozzles / C-PTFE ²	4660-4970-113
1 1/2" BSP / 11 mm nozzles / PTFE	4660-4970-114
1 1/2" NPT / 11 mm nozzles / C-PTFE ²	4660-4970-115
1 1/2" NPT / 11 mm nozzles / PTFE	4660-4970-116

¹ optional with Pin Fix connection

² suitable for use in potentially explosive atmospheres

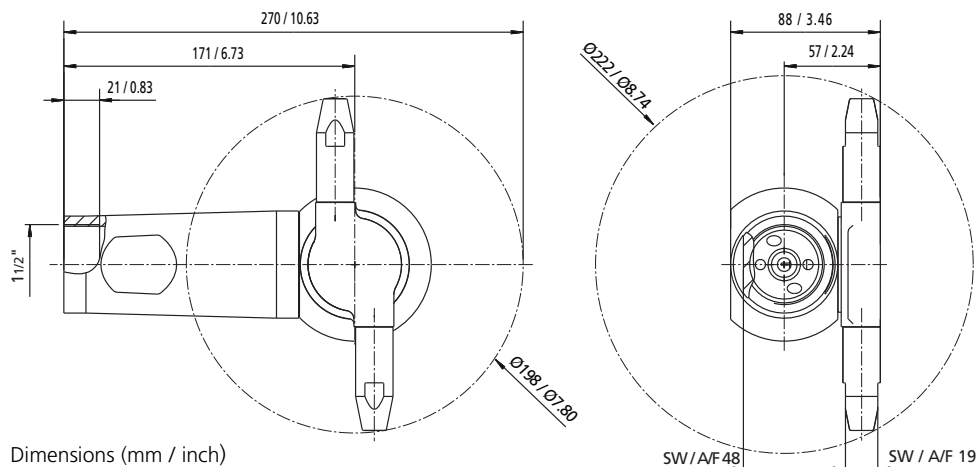

Dimensions (mm / inch)

